

# OWNER'S GUIDE

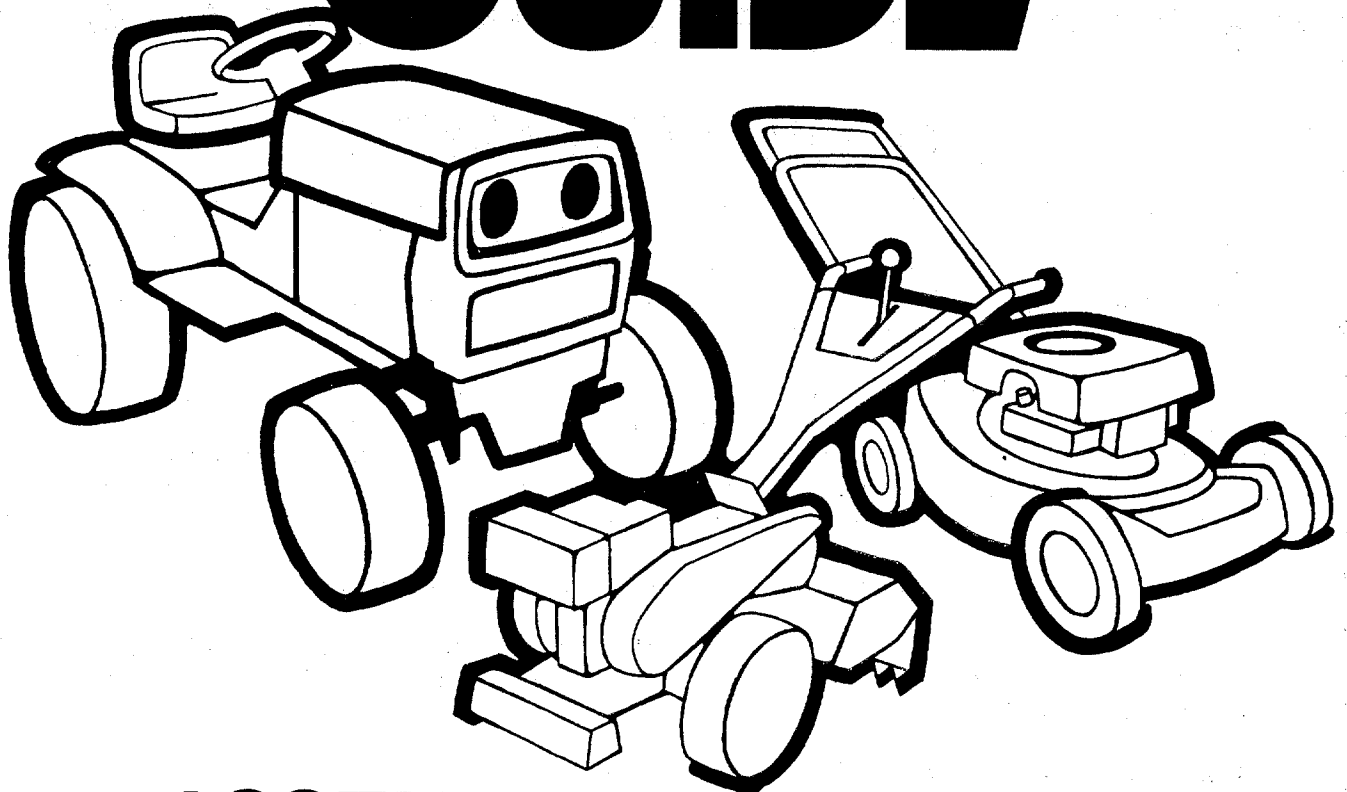

**ASSEMBLY  
OPERATION  
MAINTENANCE  
PARTS LIST**

**IMPORTANT:  
Read Safety Rules  
and Instructions**

**MODEL NUMBER  
120-270A**

**22"  
SELF-  
PROPELLED  
ROTARY  
MOWER**

# INDEX

Safe Operation Practices.....	3	Using Your Rotary Mower.....	13
Assembly Instructions.....	4	Storage.....	13
Operation Instructions.....	7	Exploded Parts View.....	16
Adjustments.....	8	Repair Parts List.....	17
Lubrication.....	10	Parts Information.....	Back Cover
Maintenance.....	11		

## LIMITED WARRANTY

For one year from the date of original retail purchase, MTD PRODUCTS INC will either repair or replace, at its option, free of charge, F.O.B. factory or authorized service firm, any part or parts found to be defective in material or workmanship. Transportation charges for any parts submitted for replacement under this warranty must be paid by the purchaser unless such return is requested by MTD PRODUCTS INC.

This warranty will not apply to any part which has become inoperative due to misuse, excessive use, accident, neglect, improper maintenance, alterations, or unless the unit has been operated and maintained in accordance with the instructions furnished. This warranty does not apply to the engine, motor, battery, battery charger or component parts thereof. Please refer to the applicable manufacturer's warranty on these items.

This warranty will not apply where the unit has been used commercially.

Warranty service is available through your local authorized service dealer or distributor. If you do not know the dealer or distributor in your area, please write to the Customer Service Department of MTD.

The return of a complete unit will not be accepted by the factory unless prior written permission has been extended by MTD.

This warranty gives you specific legal rights. You may also have other rights which vary from state to state.



**WARNING**

### TO PURCHASERS OF INTERNAL COMBUSTION ENGINE EQUIPPED MACHINERY OR DEVICES IN THE STATE OF CALIFORNIA

The equipment which you have just purchased does not have a spark arrester. If this equipment is used on any forest covered land, brush covered land, or grass covered unimproved land in the State of California, before using on such land, the California law requires that a spark arrester be provided. In addition, spark arrester is required by law to be in effective working order. The spark arrester must be attached to the exhaust system and comply with Section 4442 of the California Public Resources Code.

# IMPORTANT

It is suggested that this manual be read in its entirety before attempting to assemble or operate. Keep this manual in a safe place for future reference and for ordering replacement parts.

This unit is shipped WITHOUT GASOLINE or OIL. See operating section of this manual for proper fuel and engine oil recommendations.

Your rotary mower is a precision piece of power equipment, not a plaything. Therefore, exercise extreme caution at all times.

## SAFE OPERATION PRACTICES FOR WALK-BEHIND MOWERS

### TRAINING

1. Read the Operating and Service Owner's Manual carefully. Be thoroughly familiar with the controls and the proper use of the equipment.
2. Never allow children to operate a power mower. Only persons well acquainted with these rules of safe operation should be allowed to use your mower.
3. Keep the area of operation clear of all persons, particularly small children and pets. Stop engine when they are in the vicinity of your mower. Although the area of operation should be completely cleared of foreign objects, a small object may have been overlooked and could be accidentally thrown by the mower in any direction.

### PREPARATION

1. Thoroughly inspect the area where the equipment is to be used. Remove all stones, sticks, wire, bones and other foreign objects which could be picked up and thrown by the mower in any direction.
2. Do not operate equipment when barefoot or wearing open sandals. Always wear substantial footwear.
3. Do not wear loose fitting clothing that could get caught on the mower.
4. Check the fuel before starting the engine. Do not fill the gasoline tank indoors, when the engine is running, or while the engine is still hot. Wipe off any spilled gasoline before starting the engine.
5. Disengage the self-propelled mechanism or drive clutch on units so equipped before starting the engine.
6. Never attempt to make a wheel or cutting height adjustment while the engine is running.
7. Mow only in daylight or in good artificial light.
8. Never operate the equipment in wet grass. Always be sure of your footing. Keep a firm hold on the handle and walk, never run.

### OPERATION

1. Do not change the engine governor settings or overspeed the engine. Excessive engine speeds are dangerous.
2. Do not put hands or feet near or under rotating parts. Keep clear of the discharge opening at all times.
3. Stop the blade(s) when crossing gravel drives, walks or roads.
4. After striking a foreign object, stop the engine, remove the wire from the spark plug,

and thoroughly inspect the mower for any damage. Repair the damage before restarting and operating the mower.

5. If the equipment should start to vibrate abnormally, stop the engine and check immediately for the cause. Vibration is generally a warning of trouble.
6. Stop the engine whenever you leave the mower, before cleaning the mower housing, and when making any repairs or inspections.
7. When cleaning, repairing or inspecting, make certain the blade and all moving parts have stopped. Disconnect the spark plug wire, and keep the wire away from the plug to prevent accidental starting.
8. Before attempting to unclog the mower or discharge chute, stop the engine and be sure the blade(s) have stopped completely. Disconnect the spark plug wire and keep the wire away from the plug to prevent accidental starting.
9. Do not run the engine indoors.
10. Shut the engine off and wait until the blade comes to a complete stop before removing the grass catcher or unclogging chute.
11. Mow across the face of slopes, never up-and-down. Exercise extreme caution when changing direction on slopes. Do not mow excessively steep slopes.
12. Always disconnect electric mowers (line operated) before cleaning, repairing or adjusting.
13. Never operate mower without proper guards, plates or other safety protective devices in place.
14. Keep washout ports and other mower-housing service openings closed when mowing.

### MAINTENANCE AND STORAGE

1. Check the blade and engine mounting bolts at frequent intervals for proper tightness.
2. Keep all nuts, bolts, and screws tight to be sure the equipment is in safe working condition.
3. Never store the equipment with gasoline in the tank inside of a building where fumes may reach an open flame or spark. Allow the engine to cool before storing in any enclosure.
4. To reduce fire hazard, keep the engine free of grass, leaves, or excessive grease.
5. Check the grass catcher bag frequently for wear or deterioration. For safety protection replace only with new bag meeting original equipment specifications.

# ASSEMBLY INSTRUCTIONS

## Contents of Hardware Pack

- A (3) Hairpin Cotter
- B (1) Ferrule
- C (2) Curved Carriage Bolts 5/16-18 x 1.75" Long
- D (2) Hand Knobs
- E (1) Hex Bolt 1/4-20 x 1.50" Long
- F (1) Hex Center Lock Nut 1/4-20 Thd.
- G (2) Cable Ties

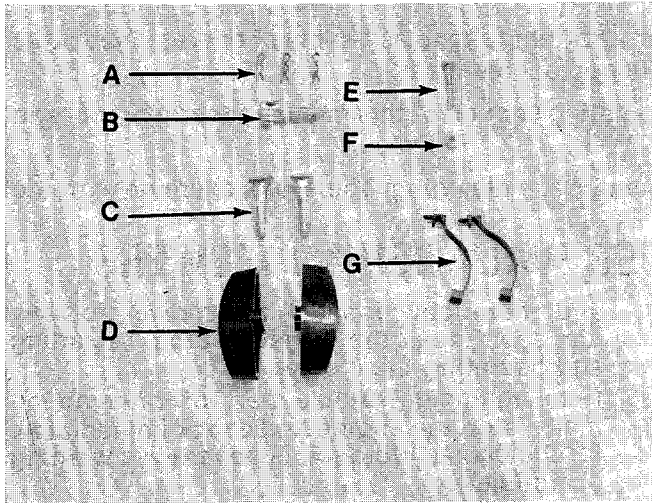

FIGURE 1.

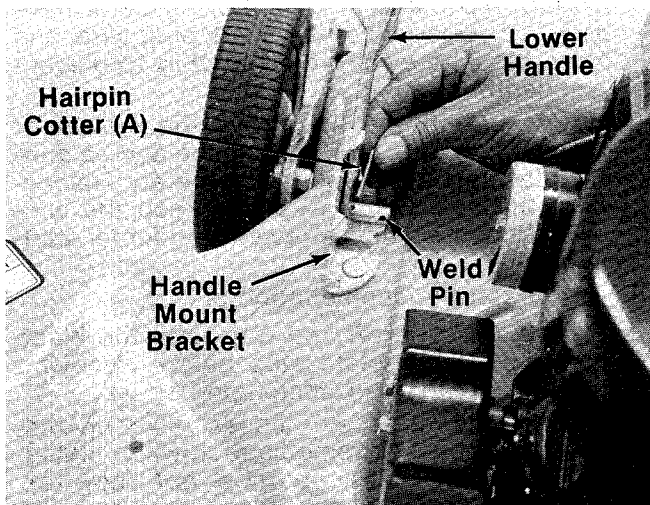

FIGURE 2.

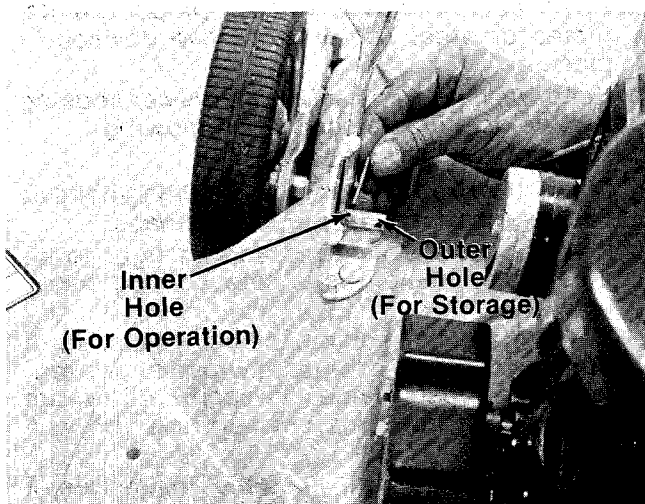

FIGURE 3.

1. Remove the lawn mower, loose parts, hardware pack and literature from the carton. Make certain all parts and literature have been removed before the carton is discarded.
2. Extend the throttle control which is attached to the engine at the rear of the mower and place on the floor. Be careful not to bend or kink control wire.
3. Fasten lower handle in position over weld pins in handle mount brackets on deck. The hole in the lower handle must be on the **left** side of the unit. Secure with hairpin cotter in inner hole on weld pin. See figure 2.

**NOTE**

Reference to right hand or left hand side of the mower is observed from the operating position.

**NOTE**

It may be necessary to pull open the ends of the lower handle. This will insure a tight fit when assembled into handle mount brackets.

**NOTE**

There are two (2) holes in the handle mount brackets. Place the lower handle against the brackets and secure with hairpin cotter in the inner hole. Inner hole is for operation. Outer hole is for storage. See figure 3.

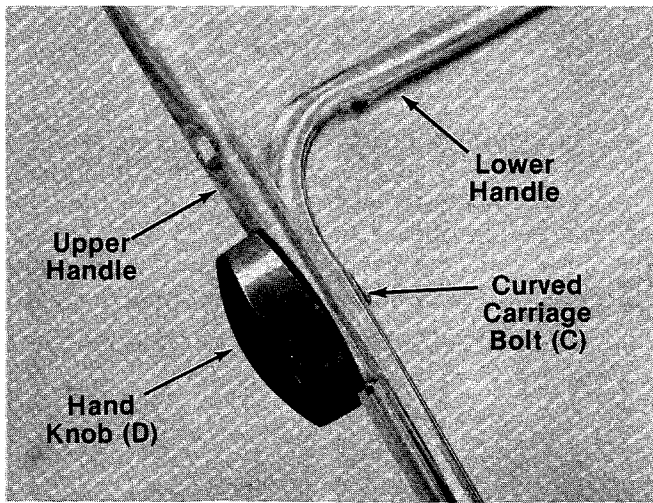

4. Assemble upper handle to lower handle. Secure with two curved carriage bolts (C) and hand knobs (D) as shown in figure 4. The hand knobs may be assembled either to the inside or the outside of the handle.



**NOTE**  
There are two height positions for the handle. See adjustment section.

FIGURE 4.

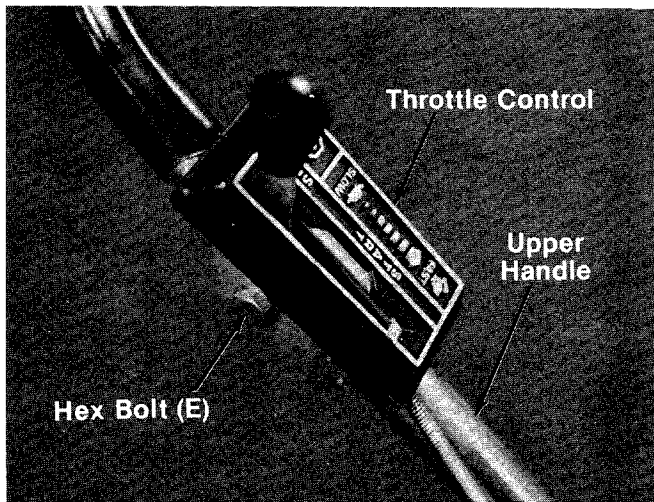

5. Place the throttle control in position on **right** side of upper handle. Secure with hex bolt (E) and lock nut (F). See figure 5.

FIGURE 5.

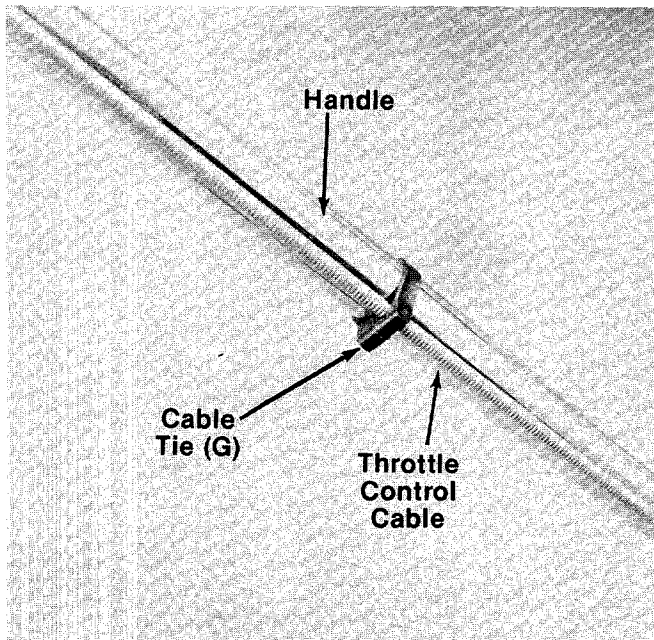

6. Secure throttle control cable to handle with cable ties (G) provided. See figure 6.

FIGURE 6.

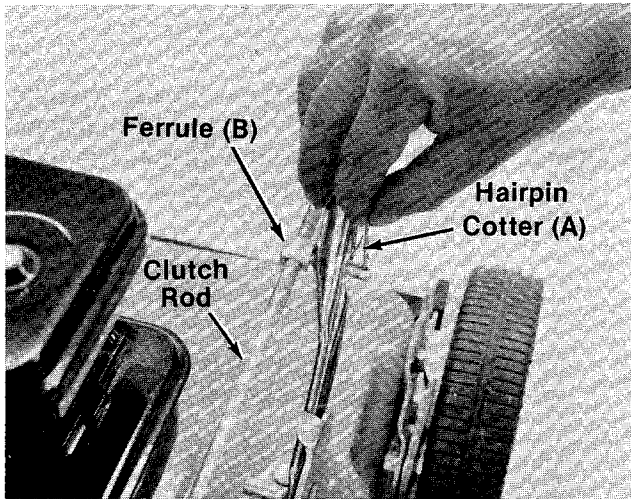

FIGURE 7.

7. Thread the clutch rod into the ferrule (A) until the ferrule lines up with the hole in the lower handle. Secure ferrule in handle with cotter pin (B) as shown in figure 7. Check for 1/8" clearance between drive pinion and front wheels. **See clutch rod adjustment** on page 9.
8. Check all nuts and bolts for correct tightness.

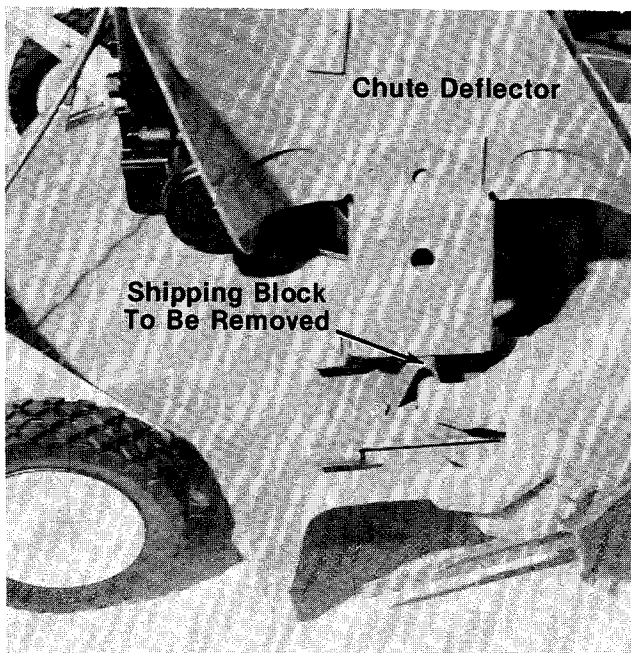

FIGURE 8.



**CAUTION**

Please note that the chute deflector on your mower is in an upright position. It is held in that position by a shipping block. This block is used for shipping purposes only. It must be removed and discarded before your mower is put into operation. See figure 8.

## OPERATION

**CAUTION**  
DO NOT OPERATE  
MOWER UNLESS  
GUARD OR ENTIRE  
GRASS CATCHER IS  
IN ITS PROPER PLACE.



**FIGURE 9.**

Keep hands and feet away from the chute area on cutting deck. See figure 9.



For shipping purposes your mower is set with the wheels in a low cutting height position. For best results, raise the cutting position until it is determined which height is best for your lawn. See adjustment section.

### BREAK-IN INSTRUCTIONS

This mower should be broken-in following the procedure described below. The added effort here will double the service life of the unit. Particular attention should be paid to the drive assembly adjustment.

1. Before starting the engine, lubricate all the bronze bearings on the drive shaft. The same oil which is used for the engine may be used for this.

2. Check drive assembly adjustment. When the handle is lifted, the clutch rod is moved to the self-propelled position. The black nylon drive pinions should mesh simultaneously with the gear tread tires. When the handle is lowered, the pinions should clear the wheels by 1/8". See clutch rod adjustment for further details.

### BEFORE STARTING

1. Follow "Break-In Instructions." See above.
2. Fill sump with oil, using a high quality detergent oil classified "For Service SC, SD, SE or MS." Use SAE 30, SAE 10W-30 or SAE 10W-40 viscosity grade oil. Nothing should be added to the recommended oil.

Place engine level. Remove oil dipstick. Fill oil sump to full mark on dipstick. Pour slowly. Capacity 1 1/4 pints.

3. Fill fuel tank, using clean, fresh, lead-free or leaded "regular" grade automotive gasoline. Fill tank completely.

DO NOT MIX OIL WITH GASOLINE.

### TO START ENGINE

1. Make sure handle is all the way back (free-wheeling position).
2. Move throttle control lever to "START" position.
3. Place foot on left side of deck and hold handle to prevent tipping the unit. Grasp starter handle as shown in figure 10 and pull out rapidly. Return it slowly to the engine. Repeat if necessary.



When starting the unit, place the unit facing a solid object to stop it if it is not correctly adjusted to be in "Neutral" position. If the unit shows signs of motion with the handle back in the "free-wheeling" position, shut off the engine immediately. Readjust the clutch rod as necessary. See clutch rod adjustment on page 9.

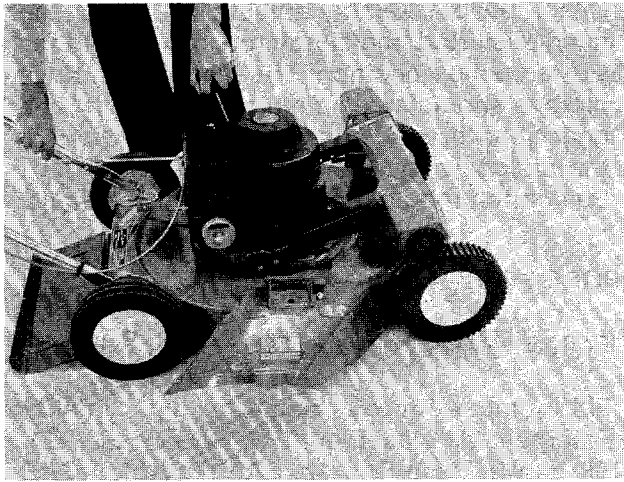

FIGURE 10.

4. After engine starts, move throttle control lever to desired speed.

#### TO STOP ENGINE

1. Move throttle control lever to "STOP" position.
2. Remove spark plug wire from spark plug and ground to prevent accidental starting while equipment is unattended.

#### TO ENGAGE DRIVE

Move the handle forward for self-propelled operation. The drive pinions will engage with the gear tread tires, and forward drive results.

To stop the forward drive, release the handle. The unit will be free-wheeling. Self-propelled drive is resumed when handle is raised.

When operating this mower, unnecessary or excessive engaging of the drive pinions with the wheels should be avoided. Minimize the number of times the handle is raised and lowered. Failure to observe this operating rule can reduce the service life of the front tires and drive pinions substantially. When engaging the self-propelled mechanism, a slight forward push on the mower as the drive pinions and the gear tread tires mesh will add to smoother and quieter operation and will add substantially to the service life of both the tires and the drive pinions.

Be sure that lawn is clear of stones, sticks, wire, or other objects which could damage lawn mower or engine. For best results and to insure more even grass distribution, do not mow when lawn is excessively wet.

### ➔ IMPORTANT

After striking a foreign object, stop the engine. Remove wire from spark plug, thoroughly inspect the mower for any damage, and repair the damage before restarting and operating the mower.

## ADJUSTMENTS

### ⚠ CAUTION

Do not at any time make any adjustment to lawn mower without first stopping engine and disconnecting spark plug wire.

#### CUTTING HEIGHT

An adjusting plate and thumb lever at each wheel position provides cutting height adjustment. Each adjusting plate has five holes. Height of cut will be changed when the thumb lever is moved from one hole to another. Simply depress the lever towards wheel and move wheel and lever assembly to desired position. See figure 11.

Cutting height will be raised as the levers are lowered. Cutting height will be lowered as the levers are raised. All wheels must be positioned at the same height.

For rough or uneven lawns, move the wheels to a position which will give a higher cutting height.

### ➔ NOTE

Clutch rod **must** be adjusted each time cutting height is changed.

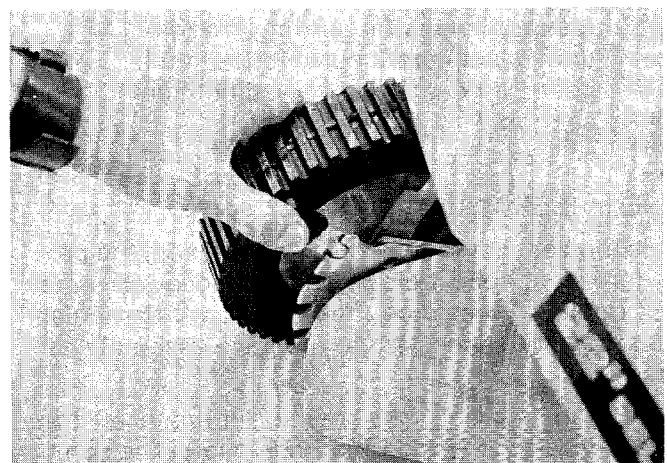

FIGURE 11.



## CLUTCH ROD ADJUSTMENT

The drive pinion should be about 1/8" from the drive wheels when the clutch is disengaged (handle is **not** pushed forward). See figure 12.

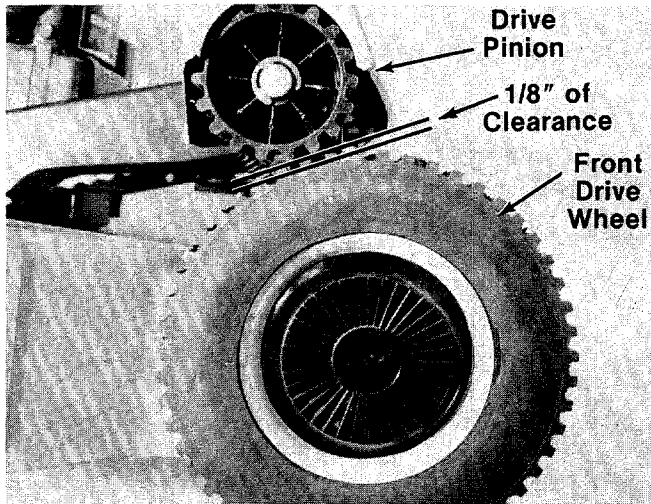

FIGURE 12.

If there is not 1/8" of clearance, proceed as follows:

1. Remove the cotter pin. See figure 7.
2. Pull the clutch rod and ferrule out of the lower handle.
3. Thread the ferrule on or off the rod as necessary.
4. Place ferrule back in position and secure with cotter pin. If the engagement and clearance are still not correct, repeat the above steps until 1/8" of clearance is obtained and the drive mechanism engages properly.

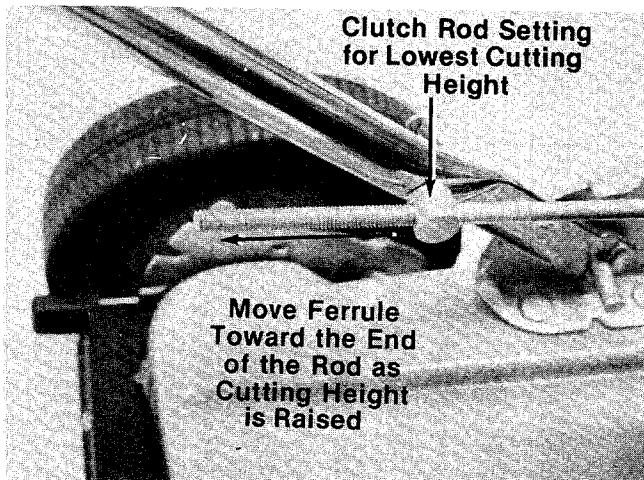

FIGURE 13.

The clutch rod must be adjusted each time the cutting height is changed. Figure 14 illustrates the clutch rod setting for the lowest cutting height. As the cutting height is raised, the ferrule must be moved toward the end of the rod. See figure 13.

## HANDLE POSITION

The upper handle can be adjusted to a high or low position. The operator of the lawn mower can easily adjust the handle position by unscrewing the two knobs, removing the two bolts and reassembling in the other position. No tools are necessary to make this adjustment. See figure 14.

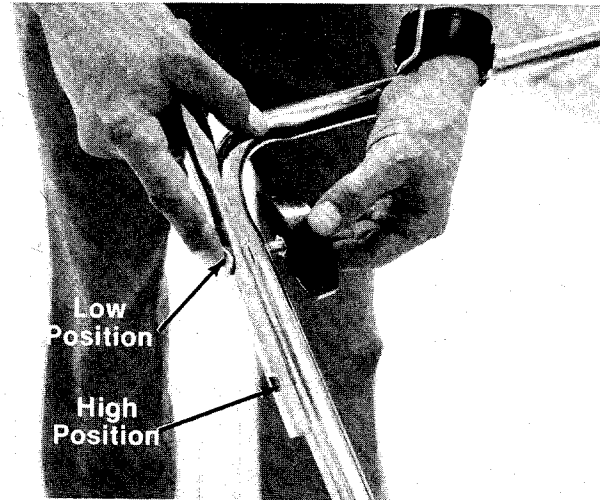

FIGURE 14.

## CHAIN ADJUSTMENT

1. Loosen (do not remove) two sems hex bolts. See figure 15.
2. Pull pivot plate forward by hand. Do not force.
3. Tighten cap screws and check chain tension. Repeat adjustment if necessary.

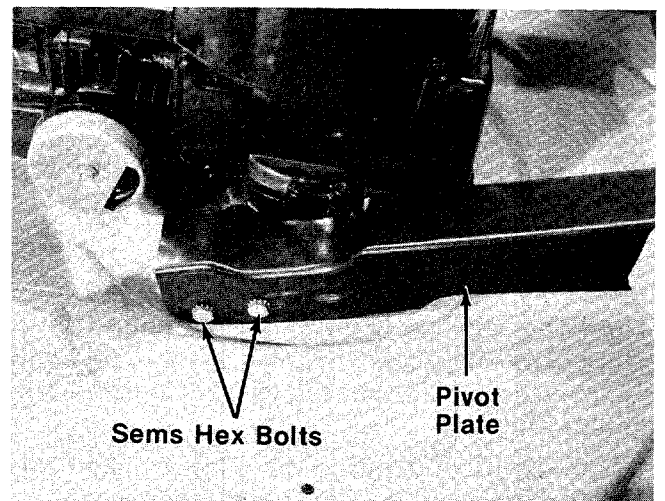

FIGURE 15.

## THROTTLE

If adjustment becomes necessary, the throttle control wire assembly can be reset as follows:

1. Loosen clamp at carburetor that holds the cable housing. See figure 16.
2. Loosen the throttle cable (wire) at the carburetor throttle lever.
3. Move throttle control lever to "FAST" position.
4. Tighten clamp (step one) at carburetor.
5. Move throttle lever on carburetor to full open throttle position and tighten screw that clamps the cable (wire).
6. Check by moving throttle knob from fast to slow several times. Cable housing should not move in clamp. Throttle should open and close fully.

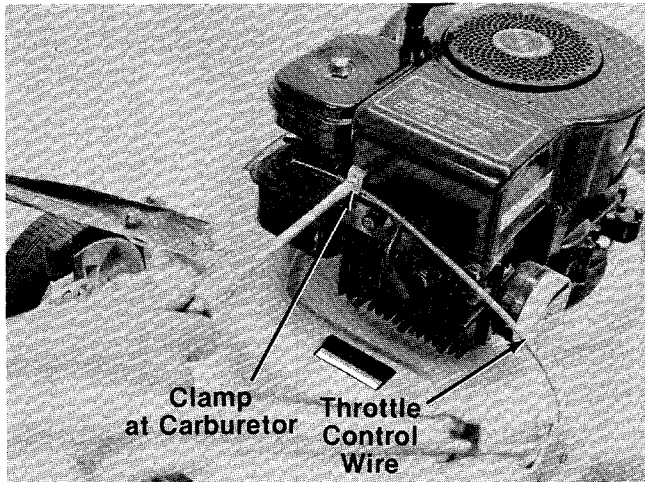

FIGURE 16.



If any adjustments are made to the engine while the engine is running (e.g. carburetor), disengage all clutches and blades. Keep clear of all moving parts. Be careful of heated surfaces and muffler.

## CARBURETOR ADJUSTMENTS (See figure 17)

Minor carburetor adjustment may be required to compensate for differences in fuel, temperature, altitude and load.

All carburetor adjustments should be made with the air cleaner on engine. Air cleaner mounting screw must be in carburetor when engine is run.

Best adjustment is made with a fuel tank half full of gasoline.

## To Adjust Carburetor:

1. Start engine and run long enough to warm it to operating temperature.  
If engine is out of adjustment so that it will not start, close the needle valve by turning it clockwise. Then open needle valve 1-1/2 turns counterclockwise.
2. Move engine control to run engine at normal operating speed.
  - a. Turn needle valve in clockwise until engine starts to lose speed (lean mixture).
  - b. Then slowly turn needle valve out counterclockwise past the point of smoothest operation until engine just begins to run unevenly (rich mixture).
  - c. Turn needle valve back in clockwise very slowly till engine runs evenly.
  - d. Final adjustment of the needle valve should be slightly to the rich side (turn counterclockwise) of the mid-point.
3. Move engine control to SLOW. Turn idle adjusting screw until a fast idle is obtained (1750 R.P.M.).
4. To check adjustment, move engine control from SLOW to FAST speed. Engine should accelerate smoothly. If engine tends to stall or die out, increase idle speed or readjust carburetor, usually to a slightly richer mixture.

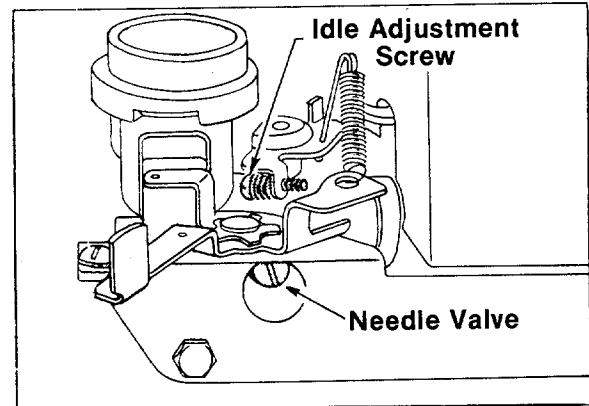

FIGURE 17.

## LUBRICATION



Always stop engine and disconnect spark plug wire before cleaning, lubricating or doing any kind of work on lawn mower.

**Wheels**—Front and rear wheel bearings are of self-lubricating Fortiflex. They require no lubrication.

**Chute Deflector**—The torsion spring and pivot point should be lubricated periodically with light oil (SAE No. 10 or 20) to prevent any rust or binding. Deflector must work freely.

**Protective Shield**—The pivot points on the protective shield should be lubricated periodically with light oil to prevent any rust or binding.

**Engine**—Follow engine manual for lubrication instructions.

**Throttle**—Periodically lubricate throttle control lever and throttle wire assembly with a few drops of light oil for ease of operation.

**Bronze Bearings**—Periodically lubricate all bronze bearings with a few drops of engine oil to minimize friction.

**Chain**—The chain should be lubricated periodically with a few drops of light oil to prevent any rust or binding. See figure 18. Use very little or no oil if unit is being used in a dry or dusty area.

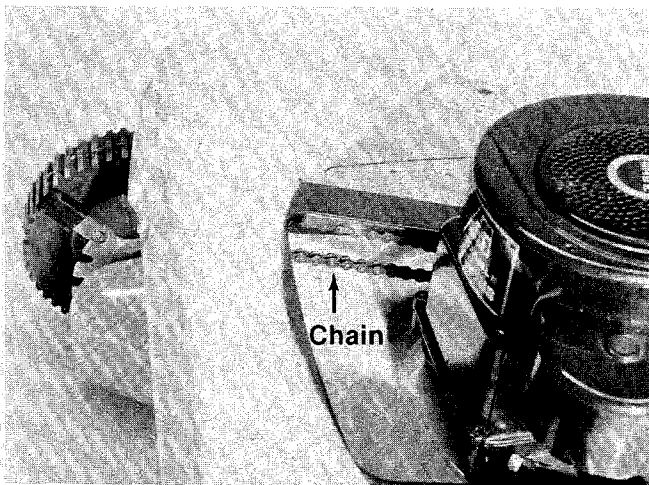

FIGURE 18.

## MAINTENANCE

### CUTTING BLADE

The blade may easily be removed for grinding or replacement as follows:

1. Remove bolt and lock washer holding blade and blade adapter to engine crankshaft.
2. Remove blade and blade adapter from engine crankshaft.
3. Remove two bolts, lock washers and nuts holding blade to blade adapter (if necessary).

When sharpening blade, follow the original angle of grind as a guide. It is extremely important that each cutting edge receives an equal amount of grinding to prevent an unbalanced blade. An unbalanced blade will cause excessive vibration when rotating at high speeds and may cause damage to the mower.

To insure safe operation of your unit, ALL nuts and bolts must be checked periodically for correct tightness.

### DECK

The underside of mower deck should be cleaned after each period of use as grass clippings, leaves, dirt and other matter will accumulate. This accumulation of grass clippings, etc., is undesirable as it will invite rust and corrosion and may cause an uneven discharge of grass clippings at the next cutting.

The deck may be cleaned by tilting the mower forward or on its side and scraping clean with a suitable tool or by washing with a stream of water from a garden hose.



Do not direct the stream of water at a hot engine as damage to the engine may result.

### ENGINE OIL

**CHECK OIL LEVEL** before starting engine and after every 5 hours of operation.

ADD oil as necessary to keep level to FULL mark on dipstick.

Before removing dipstick, clean area around dipstick to prevent dirt from entering oil fill tube.

Engine should be in a level position when checking oil.

**CHANGE OIL** after first 5 hours of operation. Thereafter change every 25 hours. Change oil while engine is warm. Oil may be drained thru drain on bottom of engine. To drain completely, always place engine level when draining thru the bottom. Oil capacity 1-1/4 pints. See figure 19.

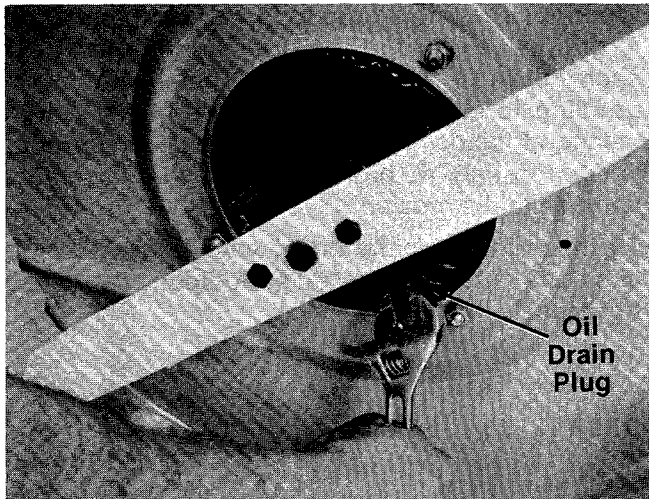

FIGURE 19.

### AIR CLEANER

**CLEAN AIR CLEANER** and re-oil element every 25 hours under normal conditions. Clean every few hours under extremely dusty conditions. Poor engine performance and flooding usually indicates that the air cleaner should be serviced. See figure 20.

1. Remove screw.
2. Remove air cleaner carefully to prevent dirt from entering carburetor.
3. Take air cleaner apart and clean.
  - a. WASH foam element in kerosene or a liquid detergent and water to remove dirt.
  - b. DRY foam completely by wrapping and squeezing in a cloth.
  - c. SOAK foam with engine oil. Squeeze to distribute and remove excess oil.
4. Reassemble parts and fasten to carburetor.

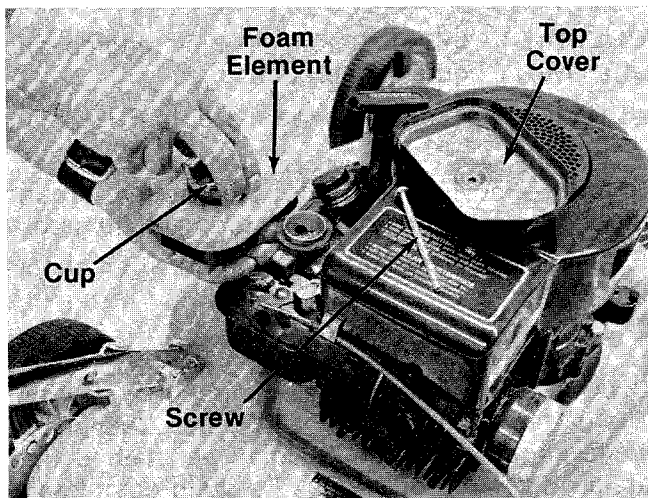

FIGURE 20.

### SPARK PLUG

The spark plug gap should be cleaned (see figure 21) and reset to a 0.030-inch clearance once a season (see figure 22). Spark plug replacement is recommended at the start of each mowing season; check engine parts list for correct plug type.

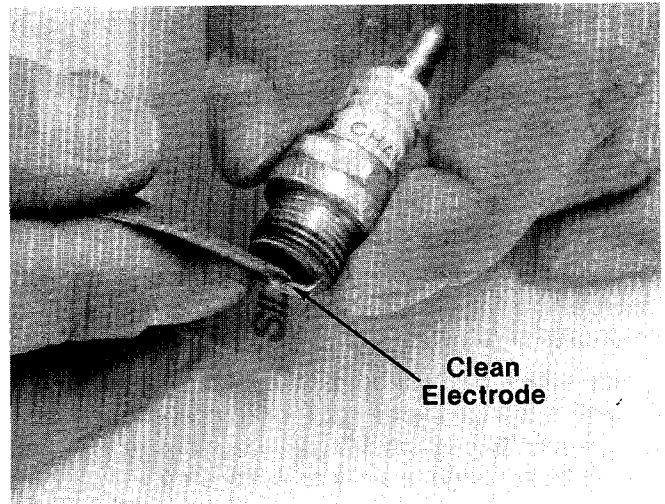

FIGURE 21.

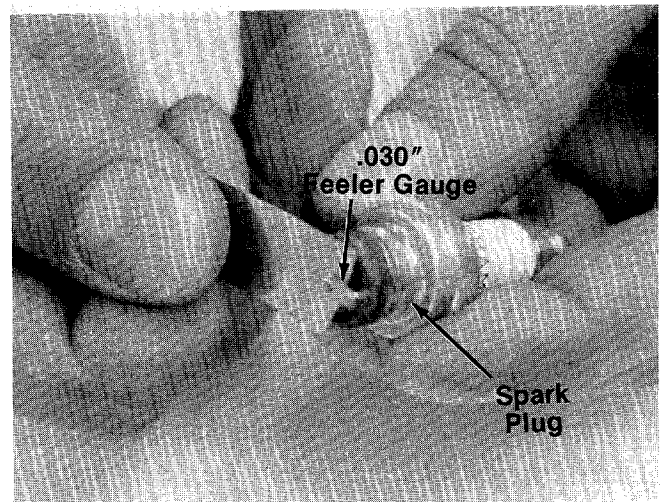

FIGURE 22.

### NOTE

Whenever the spark plug is removed for cleaning, it is advisable to replace the spark plug gasket with a new gasket.

To insure safe operation of your unit, **all** nuts and bolts must be checked periodically for correct tightness.

## USING YOUR ROTARY MOWER

For the best results, do not cut wet grass because it tends to stick to the underside of the mower, thus preventing proper discharge of grass clippings. If wet grass must be cut, reduce walking speed to help distribute the clippings more effectively.

New grass should be treated as wet grass, otherwise a normal walking speed is about the right pace for efficient mowing.

The best mowing pattern is one that allows the clippings to discharge towards the uncut part of the lawn. This permits recutting of the clippings to further pulverize them. When cutting high weeds, discharge towards cut portion, then recut at right angles to first direction.

Lawn should be cut in the fall as long as there is growth.

## OFF-SEASON STORAGE

The following steps should be taken to prepare lawn mower for storage.

1. Clean and lubricate mower thoroughly as described in the lubrication instructions.
2. Refer to Engine Manual for correct engine storage instructions.
3. Coat mower's cutting blade with chassis grease to prevent rusting.
4. Place blocks under deck to raise tires clear of floor.
5. Store mower in a dry, clean area.

## HANDLE STORAGE

To place the handle in an upright position for storage, proceed as follows.

1. Remove hairpin cotter from the ferrule on the clutch rod.
2. Remove the ferrule from the handle.
3. Move the hairpin cotters to the outer hole on weld pins. See figure 3.
4. Press inward on the bottom of the lower handle and push forward. The handle will lock in this position.

Reverse the above procedure to place the handle in the operating position. Be certain to check the clutch rod adjustment.

The handle may also be folded away completely for storage.

1. Remove hairpin cotter from ferrule in handle.
2. Pull ferrule out of the handle.
3. Replace hairpin cotter.
4. Remove hairpin cotters from inner hole on weld pins on handle mount brackets. Place in outer hole.
5. Loosen the two hand knobs on each side of the handle.
6. Pull inward on the bottom of each side of the lower handle and push forward.
7. Fold the upper handle back and down.

### To Take the Handle out of Storage Position.

1. Lift the upper handle up and towards the rear.
2. Pull the handle back until it locks into the operator's position.
3. Tighten the two hand knobs securely.
4. Move the hairpin cotters to the inner hole on the weld pins.
5. Reassemble the clutch rod. Check clutch rod adjustment.

 **NOTE**

The use of any accessory on this Rotary Mower other than those manufactured by the mower manufacturer is **not** recommended.

GRASS CATCHER Model No. 190-003A is available as optional equipment for the mower shown in this manual.



 **WARNING**

1. The mower should not be operated without the entire grass catcher or chute deflector in place.
2. The mower should not be operated without the protective shield on the rear of the deck in place.

 **NOTE**

Under normal usage bag material is subject to wear and should be checked periodically. Be sure any replacement bag complies with the mower manufacturer's recommendations.

For replacement bags, use only factory authorized replacement bag No. 764-0176.

# 120-270A

IF YOU WRITE TO US ABOUT THIS ARTICLE  
OR IF YOU ORDER REPLACEMENT PARTS AL-  
WAYS MENTION THIS MODEL & SERIAL NO  
MODEL

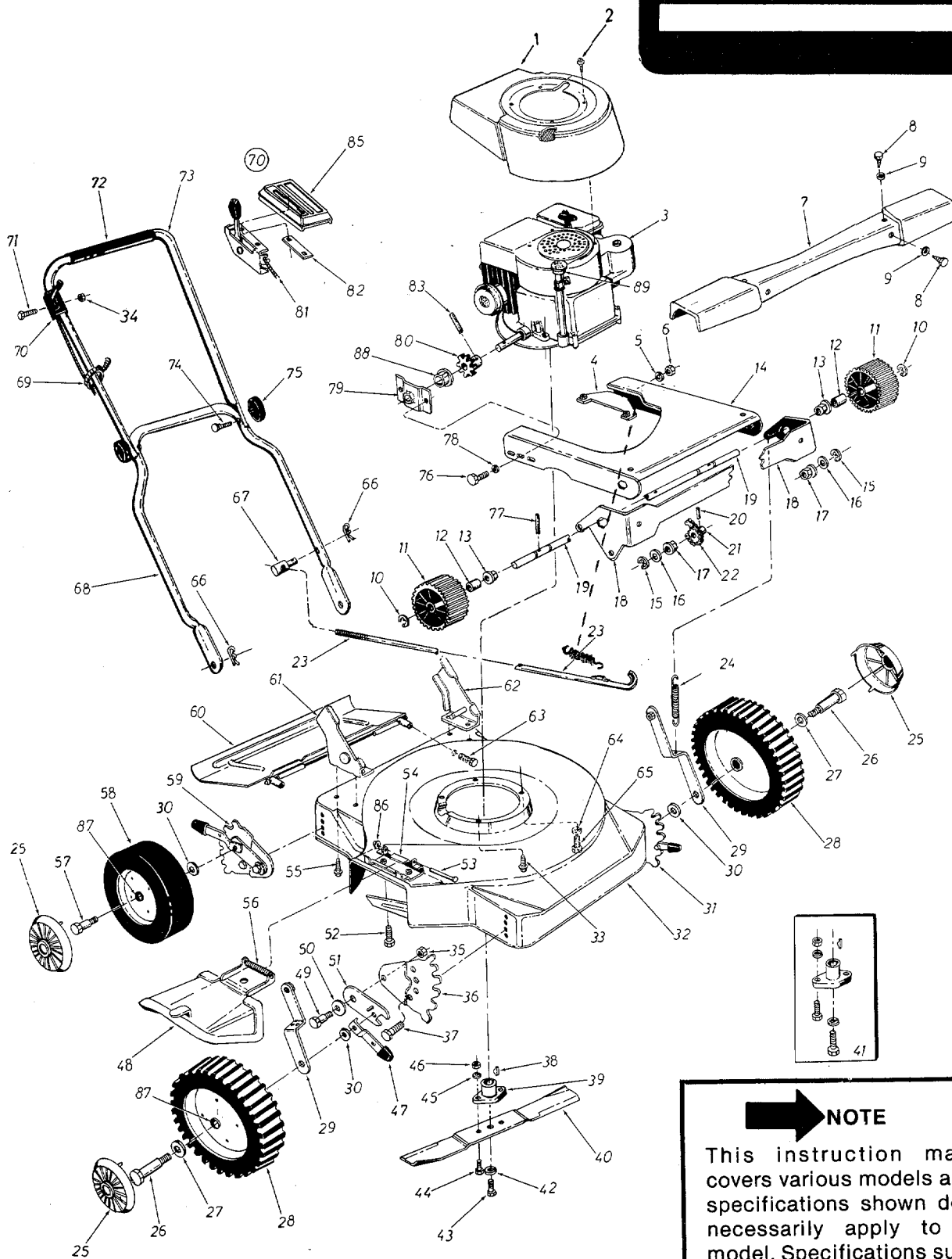

**NOTE**  
This instruction manual covers various models and all specifications shown do not necessarily apply to your model. Specifications subject to change without notice or obligation.

**PARTS LIST FOR MODEL 120-270A**

REF. NO.	PART NO.	COLOR CODE	DESCRIPTION	NEW PART	REF. NO.	PART NO.	COLOR CODE	DESCRIPTION	NEW PART
2	731-0314		Shroud		44	710-0459		Hex Bolt 3/8-24 x 1.50" Lg. H.T.	
	710-0227		Hex Wash. Hd. AB-Tap Scr. #8 x .38" Lg.		45	736-0119		L-Wash. 5/16" I.D.*	
3	—		Engine		46	712-0123		Hex Nut 5/16-24 Thd.*	
4	10381		Engine Brkt. Ass'y.		47	10530		Spring Lever Ass'y. w/Knob	
5	736-0300		Fl-Wash. .385" I.D. x.87" O.D. x .06		48	11679	—462	Chute Deflector Ass'y. Comp.	
6	712-0116		Elastic L-Nut 3/8-24 Thd.		49	738-0269		Shld. Bolt	
7	10913	—462	Drive Cover		50	736-0255		Belleville Washer	
8	710-0289		Hex Bolt 1/4-20 x .50" Lg.*		51	10619		Pivot Bar	
9	736-0222		External L-Wash. 1/4" I.D.*		52	710-0289		Hex Bolt 1/4-20 x .50" Lg.	
10	716-0106		"E"-Ring for 5/8" Shaft		53	711-0555		Pivot Pin	
11	10914		Drive Pinion		54	11130		Adapter Plate	
12	02265		Sleeve .44" Dia. x 16 Ga.		55	710-0603		Hex Wash. Hd. Self-Tap Scr. 5/16-18 x .50" Lg.	
13	748-0227		Hex Flange Brg. .630 I.D. Bronze		56	732-0253		Torsion Spring	
14	10370		Pivot Plate Ass'y.		57	738-0102		Axle Bolt—Rear	
15	716-0106		"E"-Ring for 5/8" Shaft		58	734-0843		Wheel Ass'y. Comp.—Rear	
16	736-0116		Fl-Wash. .635" I.D. x .93" O.D. x .060		59	12322		Index Plate Ass'y.—R.H.	
17	748-0227		Hex Flange Brg. .630" I.D. Bronze		60	11197	—462	Protective Shield Ass'y.—Comp.	
18	10372		Drive Support		61	14164		Handle Mtg. Brkt. Ass'y.	
19	711-0435		Drive Shaft		62	14165		Handle Mtg. Brkt. Ass'y.	
20	715-0247		Roll Pin 3/16" Dia. x 1.00" Lg.*		63	710-0567		Hex Bolt 1/4-28 x .62" Lg.	
21	10378		Sprocket Ass'y. 8 Tooth		64	736-0119		L-Wash. 5/16" I.D.*	
22	713-0135		Chain w/Master Link #48 x 26" Lg.		65	710-0442		Hex Bolt 5/16-18 x 1.50" Lg.*	
	12613		Clutch Rod		66	714-0104		Hairpin Cotter	
4	732-0433		Tension Spring		67	711-0570		Engagement Ferrule	N
25	731-0124		Hub Cap		68	749-0392		Lower Handle	
26	738-0144		Axle Bolt—Front Only		69	726-0188		Cable Tie	
27	736-0160		Fl-Wash. .385" I.D. x .87 O.D. x .06		70	746-0380		Throttle Control Ass'y. Comp.	
28	734-0880		Front Wheel Ass'y. Comp.		71	710-0606		Hex Bolt 1/4-20 x 1.50" Lg.*	
29	10918		Link Ass'y.		72	718-0145		Grip	
30	736-0105		Belleville Washer		73	749-0384		Upper Handle	N
31	12321		Index Plate Ass'y.—L.H.		74	710-0405		Curved Hd. Bolt 5/16-18 x 1 1/4"	
32	12421	—462	Deck Ass'y.		75	09966		Hand Knob	
33	710-0654		Hex Wash. Hd. Self-Tap Scr. 3/8-16 x .88" Lg.		76	710-0352		Hex Bolt 1/4-28 x 3/8" Lg.*	
34	712-0107		Hex Cent. L-Nut 1/4-20 Thd.		77	715-0246		Spring Pin Spiral 3/16 x 1.25" Lg.	
35	712-0375		Hex Cent. L-Nut 3/8-16 Thd.		78	736-0329		L-Wash. 1/4" I.D.*	
36	12323		Index Plate		79	13708		Bearing Support	
37	710-0209		Sems Hex Bolt 3/8-16 x .62" Lg.*		80	10377		Sprocket Ass'y. 8 Tooth	
38	714-0365		#6 Hi-Pro Key 5/32 x 5/8" Dia.		81	746-0381		Conduit and Wire	
39	10769		Blade Adapter Kit		82	726-0134		Speed Nut #8-32	
40	742-0125		22 Inch Blade		83	715-0247		Roll Pin 3/16" Dia. x 1.00" Lg.*	
41	10769		Blade Adapter Kit		85	731-0344		Plastic Label	
42	736-0217		L-Wash. 3/8" I.D. Heavy Duty		86	726-0106		Push Cap	
43	710-0117		Hex Bolt 5/16-24 x 1.00" Lg. H.T.		87	741-0262		Fortiflex Bearing	
					88	748-0142		Flange Bearing	
					89	751-0109		Dip Stick	

(462—Red Flake)

When ordering parts if color or finish is important, use the appropriate color code shown above. (e.g. Red Flake Finish—10913 (462).)

NOTE: The engine is not under warranty by the mower manufacturer . . . If repairs or service is needed on the engine, please contact your nearest authorized engine service outlet. Check the "Yellow Pages" of your telephone book under "Engines—Gasoline."





# PARTS INFORMATION

## POWER EQUIPMENT PARTS AND SERVICE

Parts and service for all MTD manufactured power equipment are available through the authorized service firms listed below. All orders should specify the model number of your unit, parts number, description of parts and the quantity of each part required.

<b>ALABAMA</b>	<b>BIRMINGHAM</b>
Auto Electric & Carburetor Co. ....	2625 4th Ave. S. .... 35233
<b>ARKANSAS</b>	<b>FORT SMITH</b>
Mity Mite Motors, Inc. ....	4515 South 16th Street 72901
	<b>NORTH LITTLE ROCK</b>
Sutton's Lawn Mower Shop ....	Rt. 4 Box 368. .... 72117
<b>CALIFORNIA</b>	<b>PORTERVILLE</b>
Billious ....	75 North D Street .... 93257
	<b>SAN BERNARDINO</b>
Lawn Mower Supply Co. ....	25608 E. Baseline .... 92410
	<b>SAN FRANCISCO</b>
J.W. Jewett Co. ....	981 Folsom St. .... 94107
<b>COLORADO</b>	<b>DENVER</b>
South Denver Lawn Equip. ....	527 West Evans .... 80223
<b>FLORIDA</b>	<b>JACKSONVILLE</b>
Radco Distributors ....	2403 Market St. .... 32206
	<b>OPA LOCKA</b>
Small Eng. Dist. ....	2351 N.W. 147th St. .... 33054
<b>GEORGIA</b>	<b>EAST POINT</b>
East Point Cycle & Key. ....	2834 Church St. .... 30344
<b>ILLINOIS</b>	<b>LYONS</b>
Keen Edge Co. ....	8615 Ogden Ave. .... 60534
<b>INDIANA</b>	<b>ELKHART</b>
Parts & Sales Inc. ....	2101 Industrial Pkwy. 46514
<b>IOWA</b>	<b>DUBUQUE</b>
Power Lawn & Garden Equip. ....	2551 J.F. Kennedy. .... 52001
<b>LOUISIANA</b>	<b>NEW ORLEANS</b>
Suhren Engine Co. ....	8330 Earhart Blvd. .... 70118
<b>MARYLAND</b>	<b>TAKOMA PARK</b>
Center Supply Co. ....	6867 New Hampshire Ave. 20012
<b>MASSACHUSETTS</b>	<b>SPRINGFIELD</b>
Morton B. Collins Co. ....	300 Birnie Ave. .... 01107
<b>MICHIGAN</b>	<b>LANSING</b>
Lorenz Service Co. ....	2500 S. Pennsylvania . 48910
	<b>MOUNT CLEMENS</b>
Power Equipment Dist. ....	36463 South Gratiot .. 48043
<b>MINNESOTA</b>	<b>HOPKINS</b>
Hance Distributing Inc. ....	420 Excelsior Ave. W. 55343
	<b>ST. PAUL</b>
Power Tools Inc. ....	3771 Sibley Memorial Hwy. . 55122
<b>MISSISSIPPI</b>	<b>BILOXI</b>
Biloxi Sales & Service, Inc. ....	506 Caillavet St. .... 39533
<b>MISSOURI</b>	<b>KANSAS CITY</b>
Automotive Equip. Service ....	3117 Holmes St. .... 64109
	<b>ST. JOSEPH</b>
Ross-Frazier Supply Co. ....	8th and Monterey .... 64503
	<b>ST. LOUIS</b>
Henzler, Inc. ....	2015 Lemay Ferry Rd. 63125
<b>NEW JERSEY</b>	<b>BELLMAWR</b>
Lawnmower Parts Inc. ....	717 Creek Rd. .... 08030
	<b>RUTHERFORD</b>
Feld Distributor ....	28 Glen Rd. .... 07070
<b>NEW YORK</b>	<b>CARTHAGE</b>
Gamble Dist., Inc. ....	West End Ave. .... 13619

## BRIGGS AND STRATTON, TECUMSEH AND PEERLESS PARTS AND SERVICE

Briggs & Stratton, Tecumseh and Peerless parts and service should be handled by your nearest authorized engine service firm. Check yellow pages of your telephone directory under the listing **Engines—Gasoline**, Briggs & Stratton or Tecumseh Lauson.

	<b>SYRACUSE</b>
GTP Leisure Products Inc. ....	420 Marcellus St. .... 13204
<b>NORTH CAROLINA</b>	<b>GOLDSBORO</b>
Smith Hardware Co. ....	515 N. George St. .... 27530
	<b>GREENSBORO</b>
Dixie Sales Company ....	327 Battleground Ave. 27402
<b>OHIO</b>	<b>CARROLL</b>
Stebe's Mid-State Mower Supply ...	Box 366-71 High St. ... 43112
	<b>CLEVELAND</b>
Bleckrie, Inc. ....	7900 Lorain Ave. .... 44102
	<b>WADSWORTH</b>
National Central. ....	687 Seville Rd. .... 44281
	<b>YOUNGSTOWN</b>
Burton Supply Co. ....	1301 Logan Ave. Box 929 .. 44501
<b>OKLAHOMA</b>	<b>ADA</b>
Ada Auto Supply ....	301 E. 12th St. .... 74820
	<b>MUSKOGEE</b>
Victory Motors, Inc. ....	605 S. Cherokee. .... 74401
	<b>OKLAHOMA CITY</b>
Forest Sales Inc. ....	1039 NW 63rd St. .... 73116
<b>OREGON</b>	<b>PORTLAND</b>
Kenton Supply Co. ....	8216 N. Denver Ave. ... 97217
<b>PENNSYLVANIA</b>	<b>CHESTER</b>
Stull Equipment Corp. ....	742 W. Front St. .... 19013
	<b>HARRISBURG</b>
EECO Inc. ....	4021 N. 6th St. .... 17110
	<b>PHILADELPHIA</b>
Thompson Rubber Co. ....	5222-24 N. Fifth St. ... 19120
	<b>PITTSBURGH</b>
Bluemont Co. ....	11125 Frankstown Rd. 15235
<b>TENNESSEE</b>	<b>KNOXVILLE</b>
Master Repair Service. ....	2000 Western Ave. ... 37
	<b>MEMPHIS</b>
Memphis Cycle & Supply Co. ....	421 Monroe Ave. .... 36
American Sales & Service, Inc. ....	1922 Lynnbrook .... 38116
<b>TEXAS</b>	<b>DALLAS</b>
Marr Brothers, Inc. ....	423 E. Jefferson. .... 75203
	<b>FORT WORTH</b>
Woodson Sales Corp. ....	1702 N. Sylvania .... 76111
	<b>HOUSTON</b>
Bullard Supply Co. ....	2409 Commerce St. .... 77003
	<b>SAN ANTONIO</b>
Catto & Putty, Inc. ....	414 Live Oak .... 78298
<b>UTAH</b>	<b>SALT LAKE CITY</b>
A-1 Engine & Mower Co. ....	437 E. 9th St. .... 84111
<b>VERMONT</b>	<b>BURLINGTON</b>
Vermont Hdwe. Co. Inc. ....	180 Flynn Ave. .... 05401
<b>VIRGINIA</b>	<b>RICHMOND</b>
RBI Corp. ....	963 Myers St. .... 23260
<b>WASHINGTON</b>	<b>SEATTLE</b>
Bailey's Inc. ....	1414 14th Ave. .... 98102
<b>WEST VIRGINIA</b>	<b>CHARLESTON</b>
Young's, Inc. ....	233 Virginia St., E. .... 25301
<b>WISCONSIN</b>	<b>APPLETON</b>
Automotive Supply Co. ....	123 S. Linwood Ave. ... 54911

## WARRANTY PARTS AND SERVICE POLICY

The purpose of warranty is to protect the customer from defects in workmanship and materials, defects which are NOT detected at the time of manufacture. It does not provide for the unlimited and unrestricted replacement of parts. Use and maintenance are the responsibility of the customer. The manufacturer cannot assume responsibility for conditions which it has no control. Simply put, if it's the manufacturer's fault, it's the manufacturer's responsibility; if it's the customer's fault, it's the customer's responsibility.

### CLAIMS AGAINST THE MANUFACTURER'S WARRANTY INCLUDES

1. Replacement of Missing Parts on new equipment.
2. Replacement of Defective Parts within the warranty period.
3. Repair of Defects within the warranty period.

All claims MUST be substantiated with the following information:

1. Model Number of unit involved.
2. Date unit was purchased or first put into service.
3. Date of failure.
4. Nature of failure.